

## Mechanical

### Panel Interconnect Engagement

1. Push the knurled captivated bolts through the cabinet to attach the adjacent cabinets. Refer to **Figure 1**.
2. Hand-tighten the knurled captivated bolts loosely until the cabinets are mated but still able to move for adjusting.
3. Check the top-to-bottom panel alignment to ensure the panels are level. Adjust the jacking hardware until the panels are flush.
4. Finish hand-tightening the captivated bolts as much as possible and then use a Phillips or standard screwdriver to do a final  $1/2$  to  $3/4$  turn.
5. Feel the top, bottom, and center of the seam to ensure the seam between the panels feels smooth, ensuring proper panel alignment.

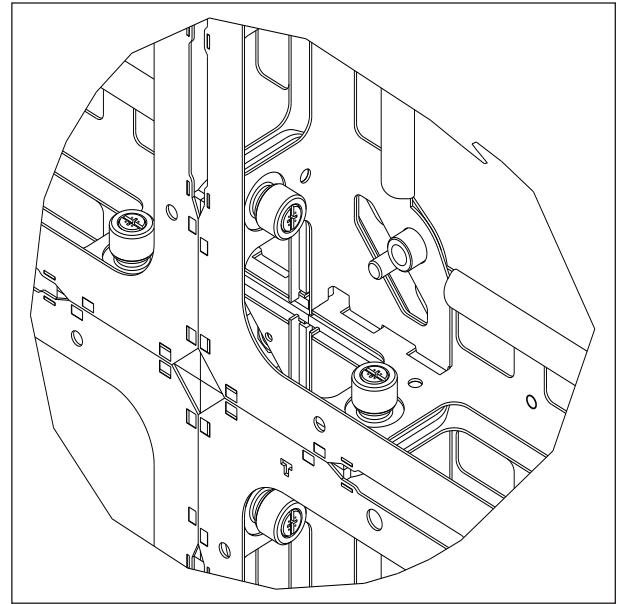

**Figure 1:** Knurled Captivated Bolt

### Self-Drilling Screw Installation

Use the contract-specific Shop Drawing to determine self-drilling screw quantities and locations per panel.

If standard  $1/4$ "-14 screws are being used, use a pilot hole size of  $13/64$ " [5.16 mm]. If alternative screws are being used, find the correct pilot hole size per the hardware specified on the contract-specific Shop Drawing.

1. Mark the locations of the self-drilling screws and drill pilot holes at those locations if pilot holes do not already exist.

**Note:** For 1x4 tubes, pilot holes must be drilled through both the front and rear walls of the tube to prevent screw strip-out.

2. Start the attachment of the self-drilling screws in the pilot holes, but do not tighten the screws down.